



सत्यमेव जयते



GOVERNMENT OF INDIA  
MINISTRY OF RAILWAYS  
(RAILWAY BOARD)

INDIAN RAILWAY STANDARD

**CODE OF PRACTICE FOR  
METAL ARC WELDING IN STRUCTURAL STEEL BRIDGES  
CARRYING RAIL, RAIL-CUM-ROAD  
OR PEDESTRIAN TRAFFIC  
(WELDED BRIDGE CODE)**

ADOPTED- 1972

REVISED- 2001

ISSUED BY

---

**RESEARCH DESIGNS AND STANDARDS ORGANISATION  
LUCKNOW - 226011**

---

## FOREWORD

1. IRS Welded Bridge Code was adopted in 1972. The need for its revision was examined in 69<sup>th</sup> BSC vide item No. 833. On the recommendations of 69<sup>th</sup> BSC, Railway Board vide letter no. 98/CE-I/BR-III/13 dated 28.7.98 ordered that revision of IRS Welded Bridge Code should be taken up by a Sub-Committee.
2. The Sub-Committee consisting of Director/B&S/RDSO, Dy. Director/M&C/RDSO, CWM/Manmad, CWM/Sabarmati and Assistant Professor(Bridges) IRICEN, Pune have prepared revised draft for IRS Welded Bridge Code. The following officers represented Sub-Committee on revision of IRS Welded Bridge Code:

|                     |                                       |
|---------------------|---------------------------------------|
| Shri S.S. Gupta     | Director/B&S/SB-II/RDSO, Lucknow      |
| Shri M.B. Vijay     | Director/B&S/Inspection/RDSO, Lucknow |
| Shri B.S. Chittoria | CWM/C.Rly./Manmad                     |
| Shri M.K. Gupta     | CWM/W.Rly./Sabarmati                  |
| Shri S.K. Ojha      | Dy. Director/M&C/RDSO, Lucknow        |
| Shri N.L. Nadagouda | AP/Bridges, IRICEN, Pune              |

Shri S.K. Chaturvedi, ADE/B&S/RDSO and Shri T. Chaki, ARO/Met/RDSO assisted the Sub-Committee in drafting and finalisation of this Code.

3. The revised draft submitted by Sub committee was discussed in extra-ordinary meeting of BSC held in February, 2000 at Pune. Railway Board's approval has been communicated vide their letter No. 2000/CE-I/Seminar/1 dated 11-9-2000.
4. The following significant changes have been made in this Code:
  - i) Indian Standard Specifications & IRS Specifications referred to have been updated. RDSO's specification have been added.
  - ii) Provisions for use of steel in fabrication of steel girder bridges have been updated in present context.
  - iii) Provision for CO2 welding has been added.
  - iv) Procedure for removal of run-on, run-off plates has been added.
  - v) Minimum size of fillet weld has been added.
  - vi) Important provisions of IS: 9595, IS: 7307 (Pt.-I) and IS: 7310 (Pt.-I) have been incorporated.
  - vii) New para on preparation of joint faces, fusion faces and assembly for welding has been added.
  - viii) Important provisions of Report No. C-277 "Guidelines on Fabrication of Welded Bridge Girders" have been incorporated.
  - ix) While revising, guidance has been taken from IS:2062, IS: 8500, IS: 9595, IS: 7307 (Pt.-I) and IS: 7310 (Pt.-I) specifications.

# CONTENTS

|              |                                                  | Page |
|--------------|--------------------------------------------------|------|
| 1.           | Scope .....                                      | 1    |
| 2.           | Terminology .....                                | 2    |
| 3.           | Materials .....                                  | 2    |
| 4.           | Drawings and Procedure Sheets .....              | 2    |
| 5.           | Butt Welds .....                                 | 2    |
| 6.           | Fillet Welds .....                               | 4    |
| 7.           | Plug Welds .....                                 | 7    |
| 8.           | Combination of Welds .....                       | 7    |
| 9.           | Cope Holes .....                                 | 7    |
| 10.          | Preparation of Joint Faces .....                 | 7    |
| 11.          | Fusion Faces.....                                | 7    |
| 12.          | Assembly for Welding .....                       | 8    |
| 13.          | Permissible Stresses in Welds.....               | 8    |
| 14.          | Reduction in Permissible Stresses.....           | 9    |
| 15.          | Structural Details.....                          | 9    |
| 16.          | Welding in Solid Web Girders .....               | 9    |
| 17.          | Strengthening of Existing Bridges .....          | 10   |
| 18.          | Safety Precautions .....                         | 11   |
| 19.          | Approval and Testing of Welding Procedures ..... | 11   |
| 20.          | Approval and Testing of Welders .....            | 11   |
| 21.          | Welding Procedures .....                         | 11   |
| 22.          | Sequence of Welding .....                        | 12   |
| 23.          | Position of Welding.....                         | 12   |
| 24.          | Tack Welds .....                                 | 13   |
| 25.          | Inter-Run Cleaning.....                          | 13   |
| 26.          | Stray Arcing on Work.....                        | 13   |
| 27.          | Inspection and Testing of Welded Joints.....     | 13   |
| 28.          | Inspection Prior to Welding .....                | 14   |
| 29.          | Inspection During Welding .....                  | 14   |
| 30.          | Inspection After Welding .....                   | 14   |
| 31.          | Acceptance Levels for Quality of Welds.....      | 15   |
| 32.          | Non-destructive Tests .....                      | 15   |
| 33.          | Marking of Defective Welds.....                  | 15   |
|              |                                                  |      |
| Appendix -A  | Procedure for Providing Plug Welds .....         | 17   |
| Appendix -B  | Fillet Weld Gauges and Their Application .....   | 18   |
| Appendix -C  | Acceptance Levels for Welds .....                | 19   |
| Figures 1-28 | .....                                            | 21   |

# INDIAN RAILWAY STANDARD CODE OF PRACTICE FOR METAL ARC WELDING IN STRUCTURAL STEEL BRIDGES CARRYING RAIL, RAIL-CUM-ROAD OR PEDESTRIAN TRAFFIC

(Welded Bridge Code)

## 1. Scope

1.1 This Code of Practice shall apply to the design, construction and inspection of welds made by Manual, automatic or semi automatic metal arc process in new and existing structural steel bridges carrying rail, rail-cum-road or pedestrian traffic. The general requirements of design, construction and inspection of structural steel bridges shall comply with IRS Steel Bridge Code and IRS Fabrication Specification.

1.2 The design and construction of welds in mild steel bars used in reinforced cement concrete, and of welds in high tensile steel are not covered by this code.

1.3 For road bridges, the design, construction and inspection of welds shall comply with the standard specifications and code of practice for road bridges issued by the Indian Roads Congress.

1.4 Any revision or addition or deletion of the provisions of this code shall be issued only through the correction slip to this Code. No cognizance shall be given to any policy directives issued through other means.

1.5 The Code makes reference to the following standards:

### 1.5.1 Indian Railway Standard Specifications

- i) B-1 Fabrication and erection of Steel Girder Bridges
- ii) M-28 Classification, testing and approval of metal arc welding electrodes.
- iii) M-39 Classification, testing and approval of submerged arc welding wire-flux combinations for use on Indian Railways.

### 1.5.2 RDSO/M&C/Specification

- i) Classification, testing and approval of CO<sub>2</sub> welding filler wires for use on Indian Railways.

### 1.5.3 Indian Standards

- 812 Glossary of terms relating to welding and cutting of metals.
- 813 Scheme of symbols for welding.
- 817 Code of practice for training and testing of metal arc welders.
- 818 Code of practice for safety and health requirements in electric and gas welding operations.
- 822 Code of procedure for inspection of welds.
- 1179 Equipment for eye and face protection during welding.

2062 Structural steel (fusion welding quality).

3016 Fire precautions in welding and cutting operations.

4353 Recommendations for submerged arc welding of mild steel and low alloy steels.

7307 (Pt-1) Approval tests for welding procedure.

7310 (Pt-1) Approval tests for welders working to approved welding procedure-fusion welding of steel.

7318 (Pt-1) Approval tests for welders when welding procedure approval is not required - fusion welding of steel.

9595 Recommendations for metal arc welding of carbon and carbon manganese steel.

**NOTE:** The latest version of IS Code /Specifications referred herein, including their amendments issued from time to time, are to be followed.

## 2. Terminology

2.1 All terms relating arc-welded construction shall have, unless specially defined in this code, the meaning assigned to them in IS: 812.

## 3. Materials

3.1 Parent metal shall be of fusion welding quality conforming to IS: 2062.

3.2 Electrodes shall conform to IRS Specification M-28. The filler wire and flux combinations for submerged arc welding

shall conform to IRS Specification M-39. Wire for CO<sub>2</sub> welding shall conform to RDSO/M&C/Specification.

3.3 All consumables shall be stored and handled with care and in accordance with the manufacturers recommendations. This shall be governed as per relevant para of IS: 9595.

## 4. Drawings and Procedure Sheets

4.1 The symbols for welding used on the drawings and procedure sheets shall be in accordance with IS: 813. If other symbols are used, a complete explanation of their meaning shall be given.

4.2 The fabrication drawings and/or welding procedure sheets prepared for direction of the welding organisation shall include the following information:

a) Specification of the parent metal, and electrodes and/or wire-flux combinations.

b) Locations, sizes, actual lengths and details, i.e. form of joint, angle between fusion faces, gap between parts, etc., of all welds.

c) Whether welds are to be made in shop or field.

d) Welding procedure, like welding sequence, pre-heating, post heating etc.

e) Details of testing and inspection requirements.

## 5. Butt Welds

5.1 **Forms and details-** All details of butt welded joints shall be in accordance

with IS: 9595 and IS: 4353 as applicable.

**5.2** Unsealed butt welds of single V, U, J and bevel types and incomplete penetration butt welds shall not be used. Sketches of different types of butt weld are given in Fig. 1.

**5.3** Intermittent butt welds shall not be used.

#### **5.4 Sealing or backing**

**5.4.1** Single V, U, J bevel or square butt welds shall generally be completed by depositing a sealing run of weld metal on the back of the joints.

**5.4.2** Where it is not practicable to deposit a run of weld metal on the back of the joint, then single V, bevel or square butt welds, welded from one side only, may be permitted, provided that another steel part of the structure or a special steel backing strip is in contact with the back of the joint and the edges of the steel parts of the joint are prepared as specified in IS: 9595 or IS: 4353, whichever is applicable, to ensure complete fusion of the parts to be joined.

**5.4.3** In all full penetration butt welds which are to be welded from both sides, the back of the first run shall be gauged out by suitable means to clean sound metal, before welding is started on the gauged out side (see Fig. 2).

#### **5.5 Butt welding parts of unequal cross-section**

**5.5.1** In butt welding steel parts in line with each other which are intended to withstand dynamic forces, and which are of unequal width, or where the difference in thickness of the parts exceeds 25% of the thickness of

the thinner part or 3 mm whichever is greater, the dimensions of the wider or thicker parts shall be reduced at the butt joints to those of the smaller part, the slope being not steeper than 1 in 5 (see Fig. 3). Where the difference in thickness of the parts does not exceed 25% of the thickness of the thinner part or 3 mm whichever is greater, the transition of thickness shall be accomplished by sloping weld faces (see Fig. 4) by chamfering the thicker part or by combination of the two methods (see Fig. 5), at an angle not steeper than 1 in 5.

**5.5.2** Where the reduction of the dimensions of the thicker part is impracticable, and/or where structures are not designed to withstand dynamic forces, the weld metal shall be built up at the junction with the thicker part to dimension at least 25% greater than those of the thinner part, or alternatively, to the dimensions of the thicker member (see Fig. 6).

**5.6 Butt Welded T Joints** - Butt weld in T joint shall be reinforced by welding as shown in Fig. 7 Flange to web connection will also fall under this category.

**5.7 Ends of butt welds** - The ends of butt joint shall be welded so as to provide the full throat thickness. This shall be done, in all cases of parent metal more than 20 mm thick and preferably in other cases also, by extending the ends of the butt welds past the edges of the parts joined by the use of run-on and run-off plates with a similar joint preparation and of reasonable thickness not less than the thickness of the part joined and of the length not less than 40 mm (see Fig. 8) If run on and run off plates are removed after completion of the welds, the ends of the weld shall be finished smooth and flush with the edges of the abutting

parts. Run on and run off plates are to be removed after completion of welds by abrasive cut off or by hacksaw blade. To avoid thermal stress as well as heat affected zone, Oxy-acetylene cut should not be permitted. If the parent metal is not more than 20 mm thick, the ends of the butt welds may be chipped or cut back to sound metal and then filled up with welds having a width not less than one and half time the 'V' opening and having the same reinforcement as adopted for the faces of the butt weld (see Fig. 9)

**5.8 Reinforcement of butt welds** - Sufficient convexity not exceeding 3 mm, shall be provided as reinforcement to ensure full cross sectional area at the joint. Where a flush surface is required, the butt welds shall be first built up as specified above and then dressed flush.

## 6. Fillet Welds

### 6.1 Types of fillet welds

**6.1.1 Normal Fillet Weld** - A normal fillet weld is one in which the depth of penetration beyond the root is less than 2.4 mm (see Fig. 10).

**6.1.2 Deep Penetration Fillet Weld** - A deep penetration fillet weld is one in which the depth of penetration beyond the root is 2.4 mm or more (see Fig. 10). It shall be used only by agreement between purchaser and contractor, and tests shall be agreed between purchaser and contractor to verify that the requisite root penetration is being obtained.

**6.2 Size** - The size of normal fillet weld shall be taken as the minimum leg length (see Fig. 11). The size of a deep penetration fillet weld shall be taken as the

minimum nominal leg length plus 2.4 mm (see Fig. 12) The minimum size of the first run or of a single run fillet welds shall be as given in table-I. Minimum size of fillet weld shall be as given in table II to avoid the risk of cracking in the absence of pre-heating.

**Table-I** Minimum size of first run of a fillet weld (Clause 6.2)

| Thickness of thicker part            | Minimum size |
|--------------------------------------|--------------|
| 6 mm up to and including 20 mm       | 5 mm.        |
| Over 20 mm up to and including 32 mm | 6 mm.        |
| Over 32 mm up to and including 50 mm | 8 mm.        |

**Table-II** Minimum size of a fillet weld

| Thickness of thicker part            | Minimum size |
|--------------------------------------|--------------|
| Upto and including 6 mm              | 3 mm         |
| Over 6 mm upto and including 12 mm   | 4 mm         |
| Over 12 mm upto and including 18 mm  | 6 mm         |
| Over 18 mm upto and including 36 mm  | 8 mm         |
| Over 36 mm upto and including 56 mm  | 10 mm        |
| Over 56 mm upto and including 150 mm | 12 mm        |
| Over 150 mm                          | 16 mm        |

**Note:** (1) When the minimum size of the first run of fillet weld and /or minimum size

of the fillet weld as given in Table-I and Table-II is greater than the thickness of the thinner part, the minimum size of the weld shall be equal to the thickness of the thinner part. The thicker part shall be adequately pre-heated to prevent cracking of the weld.

(2) Where the thicker part is more than 50 mm in case of steel to IS: 2062 special precautions like pre-heating as per IS: 9595 shall be taken to ensure weld soundness.

**6.3 Effective throat thickness** - The effective throat thickness of a fillet weld shall be taken as 'K' times fillet size where 'K' is a constant, given in as per Fig. 13, for different angles between fusion faces. All fillet welds shall have a flat or convex face. In no case, except at the outside of a corner joint shall the convexity exceed the value given by the formula  $0.1S + 0.76$  mm, where S is size of weld in mm.

**6.4 Angle between fusion faces** - Fillet weld shall not be used for connecting parts, whose fusion faces form an angle of more than  $120^\circ$  or less than  $60^\circ$ , unless such welds are demonstrated by practical tests to develop the required strength.

**6.5 Effective length** - The effective length of fillet weld shall be that length only, which is of the specified size and required throat thickness. It shall be taken to be the actual length of the weld minus twice the weld size. This deduction need not be made in the case of end and side fillets, which are returned continuously around the corner for a minimum length of twice the weld size.

**6.6 Effective area** - The effective area of a fillet weld shall be the effective throat thickness multiplied by the effective length.

**6.7 Minimum length** - The effective length of a fillet weld designed to transmit

loading shall not be less than four times the size of the weld, subject to minimum of 40 mm.

## **6.8 Intermittent fillet welds**

**6.8.1** Intermittent fillet welds may be used in structures not subjected to dynamic loading, to transfer calculated stress across a joint when the strength required is less than that developed by a continuous fillet weld of the smallest allowable size for the thickness of the parts joined.

**6.8.2** Load carrying intermittent fillet welds shall not be used in members subjected to dynamic loading, except for connecting intermediate stiffeners to webs of beams and girders, subject to the provisions of clause 16.3.

**6.8.3** Intermittent fillet welds shall not be used where they would result in the formation of rust pockets.

**6.8.4** Chain intermittent welding is to be preferred to stagger intermittent welding.

**6.8.5** The distance along an edge of a part between effective lengths of consecutive intermittent fillet welds, whether the welds are in line or staggered on alternate sides of the edge, shall not exceed 12 times the thickness of the thinner part and shall in no case exceed 150 mm. This requirement shall not be taken into account in complying with the requirements of clauses 6.4 and 6.8 of IRS Steel Bridge Code.

**6.8.6** In a line of intermittent fillet welds, there shall be a weld at both ends of the parts connected. For staggered welds, this shall apply to both sides.

**6.8.7** In built up members in whose parts



are connected by intermittent filled welds, continuous longitudinal fillet welds shall be used at the end for a length not less than the width of the part concerned.

### 6.9 Fillet welds applied to the edge of a plate or section

6.9.1 Where a fillet weld is applied to the square edge of a part, the specified size of the weld shall generally be at least 1.5 mm less than the edge thickness, in order to avoid melting down of the outer corner, (see Fig. 14).

6.9.2 Where a fillet weld is applied to the rounded toe of a rolled section, the specified size of the weld shall generally not exceed  $3/4$  of the thickness of the section at the toe (see Fig. 14).

6.9.3 Where a fillet weld equal in size to the thickness of the section at the toe of a rolled section or at the square edge of a plate is required from design considerations and is specially designated in the drawing, the toe or edge shall be specially built up with weld metal in such a manner as to ensure full throat thickness, full fusion area and no injury to the parent metal (see Fig. 15 & 16).

6.10 End fillets - When end fillets are used alone, each fillet shall be returned as a side fillet for a minimum length equal to twice the size of the weld, and this returned length shall be disregarded in calculating the strength of the joint.

### 6.11 Fillet welds in slots or holes

6.11.1 When welding inside a slot or a hole, in a plate or other part, in order to join the same to an underlying part, fillet welding may be used along the wall or walls of the

slot or the hole, but the later shall not be filled with weld metal or partially filled in such a manner as to form a direct weld metal connection between opposite wall.

6.11.2 The dimensions of the slot or hole shall comply with the following limits in terms of the thickness of the steel part in which the slot or hole is formed.

- (i) The width or diameter to be not less than three times the thickness or 25 mm whichever is greater.
- (ii) Corners at the enclosed ends of slots to be rounded with a radius not less than 1.5 times the thickness or 12 mm whichever is greater.
- (iii) The distance between the edge of the part and edge of the slot or hole or between adjacent slots and/or holes not to be less than twice the thickness when measured along the direction of stress and five times the thickness when measured normal to the direction of stress.

6.12 End Returns - Fillet welds terminating at the ends or sides of parts or members shall be returned continuously around the corner for a distance of not less than twice the size of the weld. This provision shall apply particularly to side and end fillet welds joining brackets, beam seatings and similar attachments at the tension side of such connections.

6.13 Bending about a single fillet - A single fillet weld shall not be subjected to bending moment about the longitudinal axis of the fillet (see Fig. 17).

### 6.14 Lap Joints

6.14.1 The minimum overlap of parts in stress carrying lap joints shall be four times

the thickness of the thinner part. Unless opening out of the parts is prevented, they shall be connected by at least two transverse or two longitudinal fillet welds (see Fig. 18).

**6.14.2** If longitudinal fillet welds are used alone in lap joints of end connections, the length of each fillet weld shall be not less than the perpendicular distance between them. The transverse spacing of longitudinal fillet welds used in end connections shall not exceed sixteen times the thickness of the thinner part connected. The longitudinal fillet welds may be in slots in addition to those along the edges, to comply with this provision.

## 7. Plug Welds

**7.1** Plug welds shall not normally be provided and in any case shall not be designed to carry stresses. Where unavoidable, the procedure laid down in Appendix A shall be followed.

## 8. Combination of Welds

**8.1** If butt and fillet welds are combined in a single joint, the allowable capacity of each shall be separately computed with reference to the axis of the group in order to determine the allowable capacity of the combination.

**8.2** Butt welds in parts or members, subjected to dynamic loading, shall not be supplemented by splice plates attached by fillet welds.

## 9. Cope Holes

**9.1** Cope hole is a semi circular notch in between web plate and flange plate to

disconnect junction of welds(see Fig. 19).

**9.2** Provision of cope hole in welded girders is not required when the following conditions are satisfied;

- i) Butt welds in flanges and web are made by automatic sub-merged arc welding prior to assembling web and flanges together,
- ii) Weld reinforcement is dressed flush both at top and bottom by grinding/machining and
- iii) Weld is tested by radiographic/ultrasonic method.

## 10. Preparation of Joint Faces

**10.1** Preparation of joint faces shall be done as per IS: 9595.

## 11. Fusion Faces

**11.1** The preparation of fusion faces, angle of preparation root radius and root face shall be as specified in IS: 9595 and IS:4353. Where the gap between the root faces of a butt joint is excessive, the gap shall not be bridged since this procedure often leads to cracking. The fusion faces of the joint shall be built-up with weld metal to give the appropriate gap before the weld proper is commenced.

**11.2** The preparation of fusion faces, angle of bevel, root radius and root face shall be such that the limits of accuracy required by the appropriate application standard can be achieved. When however, no appropriate application standard exists and this standard is itself to be used, it is recommended that, for manual welding, the tolerances on limits of gap and root face should be  $\pm 1$  mm on the specified

dimensions for material upto and including 12 mm thick and  $\pm 2$  mm for material over 12 mm thick. The tolerance on the included angle between the fusion faces of a V preparation is recommended to be  $\pm 5$  degree and for U and J preparations + 10 degree. For an automatic process, closer limits are necessary and particular requirements depend on the characteristics of the process.

**11.3** It shall be ensured, if necessary, by suitable non-destructive tests that the fusion faces and adjacent surfaces shall be free from cracks, notches or other irregularities which might be the cause of defects or would interfere with the deposition of the weld.

**11.4** Fusion faces and the surrounding surfaces shall be free from heavy scale, moisture, oil, paint or any other substance which might affect the quality of the weld or impede the progress of welding. Certain proprietary protective coatings are specially formulated with the intention that they should not interfere with welding. The use of such coatings is not excluded by the requirements of this clause but shall be demonstrated by means of specimen welds that the coating complies with the above requirements.

## **12. Assembly for Welding**

**12.1** Parts to be welded shall be assembled such that the joints are easily accessible and visible to the operator.

**12.2** Jigs and manipulators shall be used, where practicable, so that the welding can be carried out in the most suitable position. Jigs shall maintain the alignment with the minimum restraint so as to reduce the possibility of locked in-stress.

## **13. Permissible Stresses in Welds**

**13.1** Since fatigue strength of welded structures depends upon the constructional details, this shall be decided before the permissible stresses and consequently the size of members and weld sizes are determined.

**13.2** Stresses due to dead load, live load and impact, stresses resulting from curvature and eccentricity of track, and secondary stresses as defined in clause 3.3.2 (a) of IRS Steel Bridge Code, shall only be considered for effects due to fatigue. All other items mentioned in clause 3.1 of IRS Steel Bridge Code, and secondary stresses as defined in clause 3.3.2 (b) thereof should be ignored when considering fatigue.

**13.3 Butt welds** - Stresses in butt welds shall not exceed the permissible stresses of the parent metal as specified in IRS Steel Bridge Code.

### **13.4 Fillet welds**

**13.4.1** The basic permissible stress in fillet welds based on a thickness equal to the throat thickness shall be  $100 \text{ N/mm}^2$  ( $10.2 \text{ kg/mm}^2$ ) where a fillet weld is subjected to shear stress in two directions, the actual stress shall be taken as the vector sum of the separate shear stresses and shall not exceed  $100 \text{ N/mm}^2$  ( $10.2 \text{ kg/mm}^2$ ).

**13.4.2** Load carrying fillet welds in dynamically loaded structures shall be designed such that the stress on the total effective area of fillet welds does not exceed the relevant values specified in Table for Class 'G' Constructional details, Appendix 'G' to IRS Steel Bridge Code, subject to a maximum of  $100 \text{ N/mm}^2$  ( $10.2 \text{ kg/mm}^2$ ).

**13.4.3** Load carrying fillet welds in dynamically loaded structures shall be designed so that secondary bending stresses are not developed (e.g. single lap joints shall not be used).

#### **14. Reduction in Permissible Stresses**

**14.1** The permissible stresses for field welds of structural members shall be reduced to 80% of those specified in clauses 13.3 and 13.4. Field welds shall not be adopted for bridges carrying road/railway loading without the specific approval of the Board.

**14.2** If over-head welds are unavoidable, the stresses permitted shall be 80% of those specified in clauses 13.3 and 13.4 and modified by clause 14.1 if field welding is involved.

**14.3** In structures subjected to dynamic loading, tensile or shear stresses in butt welds shall not exceed 66% of the permissible stresses as specified in clause 13.3 and as modified by clauses 14.1 and 14.2 as applicable, unless the welds are examined radiographically, ultrasonically or other non-destructive testing methods which are equally effective and present satisfactory evidence to the Engineer that welds are meeting the quality requirement.

#### **15. Structural Details**

**15.1** Changes in section shall be gradual and re-entrant notch-like corners shall be avoided.

**15.2** Attachment of fittings and making openings at locations of severe fatigue stress shall preferably be avoided.

**15.3 Packings** - Where a packing is used between two parts, the packing and the welds connecting it to each part shall be capable of transmitting the load between the parts, except where the packing is too thin to carry the load or permit the provision of adequate welds, when it shall be trimmed flush with the edges of the narrower part and the load shall be transmitted through the welds alone, the welds being increased in size by an amount equal to the thickness of the packing.

#### **15.4 Arrangement of welds**

**15.4.1** Fillet welds at right angles to the lines of principal stresses in a plate subjected to tension shall be avoided in dynamically loaded structures.

**15.4.2** Accumulation of weld joints in a single location shall be avoided (See Fig. 20).

**15.4.3** Sizes or lengths of fillet welds shall be sufficient to provide for better distribution of stress. Excessive sizes or lengths shall not be specified.

#### **16. Welding in Solid Web Girders**

##### **16.1 Flange plates**

**16.1.1** Each flange shall, as far as possible, particularly in dynamically loaded structures, consist of a single section rather than of two or more sections super-imposed. The single section may comprise a series of sections laid end to end and effectively welded at their junctions.

**16.1.2** If the use of curtailed flange plates can not be avoided the end of the plate shall be tapered in plane to a rounded end and welded continuously round the end.

**16.1.3** In dynamically loaded structures, flange plates laid end to end shall be joined by butt welds, and welded cover plates shall not be used. Joints in flange plates shall be butt welded and dressed flush before assembling.

**16.1.4** Where the flange consists of more than one section, the butt joints shall be staggered.

**16.1.5** Welded cover plates, where used in structures not subjected to dynamic loading, shall have enough welds on either side to develop the load 5% more than that of the element spliced.

**16.1.6** The flange plate, welded directly to the web plate, shall not be more than 50 mm thick when steel conforms to IS: 2062.

**16.2 Web plates** - Splices in the webs of plate girders and rolled sections used, as beams shall be made by butt welds dressed flush on all faces, in the case of dynamically loaded structures. In the case of structures not subjected to dynamic loading, splice plates may be used independently and not to reinforce a butt-welded splice.

### **16.3 Intermediate stiffeners**

**16.3.1** Where intermediate stiffeners are connected to the web by intermittent fillet welds placed in pairs, one weld on either side of the stiffeners, the effective length of each weld shall be not less than four times the thickness of the stiffeners, subject to the provisions of clause 6.7.

**16.3.2** Where staggered intermittent fillet welds are used, the effective length of each weld shall be not less than 10 times the thickness of the stiffener, subject to the provisions of clause 6.7.

**16.3.3** Fillet welds placed on one side only of the stiffener shall not be used.

**16.3.4** Intermediate stiffeners carrying cross bracings or diaphragms shall not be connected to the web by intermittent fillet welds.

**16.3.5** Intermediate stiffeners shall be located away from web splices.

### **17. Strengthening of Existing Bridges**

**17.1** All provisions of this code, applicable to new welded bridge work, shall apply equally to strengthening of existing bridges except as modified by clauses 17.2 to 17.7.

**17.2** Where a compression member is strengthened by welding while under load, the work shall be carried out in such a way that -

- (a) The least radius of gyration is substantially increased; and
- (b) Large compression shrinkage stresses are not induced in the extreme fibres.

**17.3** Strengthening of existing bridges by welding shall not be done unless tests prove that the parent metal is suitable for the purpose.

**17.4** The details of design for strengthening shall be made taking into consideration the weakening effect of stress raisers on the fatigue strength of the parent metal.

**17.5** If material is added to a member carrying dead load stress in excess of  $19.6 \text{ N/mm}^2$  ( $2.0 \text{ kg/mm}^2$ ) for strengthening, it is desirable to relieve the member of dead load stress.

17.6 In all cases where the dead load stress is not relieved, the permissible stress in the new material added for strengthening shall be the allowable unit stress in the original member minus the dead load stress in the original member.

17.7 When welding is used for strengthening an existing riveted or bolted connection, the rivets shall be assumed to carry the dead load, provided they are capable of carrying it without overstress and welding is carried out without relieving the dead load stress. The welds in such cases shall be designed to carry all loads other than dead load. In case the rivets or bolts are overstressed even by dead load, or the strengthening is done after relieving the dead load stress, the weld shall be designed to carry all loads including the dead load.

## 18. Safety Precautions

18.1 Provisions of IS: 818, IS: 1179 and IS: 3016 shall generally apply for safety and health requirements during welding operations.

## 19. Approval and Testing of Welding Procedures

19.1 Welding procedure test shall be carried out in accordance with IS:7307(Part-I) to demonstrate, by means of a specimen weld of adequate length on a steel representative of that to be used, so as to confirm that satisfactory weld is achievable with the welding procedure to be used for fabrication.

19.2 Provisions of IS: 9595 and IS: 4353, shall generally be followed, as applicable, for welding procedure, details of workmanship, correction of weld faults,

peening, painting, etc. In case any of the provisions contained therein contravene the provisions made on this code, the latter shall be followed.

19.3 In addition to the provisions of IS: 4353 the Inspector may, where deemed necessary, require a sample joint having the same cross-section as the joint to be used in construction and a length of at least 300 mm to be welded with the wire, flux current, arc voltage and speed of travel that are proposed to be used and a macroetched cross section of the welded joint prepared as a demonstration that the specified requirements will be met, when the welding current, arc voltage and speed of travel are established by a test made in accordance with requirements of this clause, they shall be kept within the following limits of variations

|                 |      |
|-----------------|------|
| Welding current | ±10% |
| Arc Voltage     | ± 7% |
| Speed of travel | ±15% |

## 20. Approval and Testing of Welders

20.1 The welders shall be trained in accordance with IS: 817. The welders shall be subjected to appropriate qualifying tests specified in IS: 7310 (Pt-I).

## 21. Welding Procedures

21.1 Welding work shall be given to a contractor who does produce satisfactory evidence of his ability to handle the work in a competent manner. The contractor shall also prove the ability of the operator/Welders employed by him to produce welds of the required strength. The contractor shall employ a competent welding supervisor to ensure that quality of materials and the standard of workmanship

comply with the requirements laid down in this code.

**21.2** The sizes and length of welds shall not be less than those specified in the drawings nor shall they be substantially in excess of the requirements without prior approval of the Engineer. The location of welds shall not be changed without prior approval of the Engineer. Welds shall preferably be made in flat position.

**21.3** In case of welds in structures subjected to dynamic loading, adequate means of identification, either by identification stamp or other records shall be provided to enable each weld to be traced to the welding operator by whom it was made.

**21.4** During the entire welding of cooling cycle, the joints shall not be subjected to any external forces or shocks.

**21.5** Freedom of movement of one member of a joint shall be allowed wherever possible. No butt joint shall be welded without allowing one component, freedom of movement of the order of 1.5 mm.

**21.6** In making welds under conditions of severe external shrinkage restraint, the welding shall be carried out with electrodes having type 6 covering as per IRS:M-28 Specification.

**21.7** In case of welding using direct current, earthing on the work piece to be welded shall be connected carefully at more than one location with a view to avoid "Arc Blow" during welding.

**21.8** All welds should be done by submerged arc welding process either fully automatic or semi-automatic. Carbon-di-

oxide (CO<sub>2</sub>) welding or manual metal arc welding may be done only for welds of very short runs or of minor importance or where access of the locations of weld does not permit automatic or semi-automatic welding.

**21.9** Neither the depth of fusion nor the maximum width in the cross section of weld metal deposited in each weld pass shall exceed the width of the face of the weld pass. (see Fig. 21 & 22)

## **22. Sequence of Welding**

**22.1** The sequence of welding shall be such that when possible the members, which offer the greatest resistance to compression, are welded first.

**22.2** The welding in the thinnest element of a section (usually the web in case of beams) shall be done prior to the welding of the thicker elements (usually the flanges in case of beams).

**22.3** In making butt welded joints in rolled shapes, the sequence and procedure of welding shall take into account unequal amount of expansion or contraction in elements being welded.

**22.4** Splices in each component part of a solid web girder or built-up member shall be made before such component part is welded to other component part of the member.

## **23. Position of Welding**

**23.1** For fabrication of steel bridge girders the following positions of welding shall be adopted.

- I) Flat and horizontal position for Submerged Arc Welding (SAW) and
- II) Horizontal or horizontal-vertical position for welding done using manual metal Arc welding (MMAW) or CO<sub>2</sub> welding.

**Note** – Different positions have been shown diagrammatically in Fig. 23.

**23.2** All butt welds by the submerged arc process shall be made in the flat position. Fillet welds may be made in either flat or horizontal-vertical position. The size of the single pass fillet welds made in the horizontal-vertical position shall not exceed 8 mm.

## **24. Tack Welds**

**24.1** Tack welds shall be not less than the throat thickness or leg length of the root run to be used in the joint. The length of the tack weld shall not be less than four times the thickness of the thicker part or 50 mm whichever is the smaller

**24.2** Where a tack weld is incorporated in a welded joint, the shape, size and quality shall be suitable for incorporation in the finished weld and it shall be free from all cracks and other welding defects. Tack welds, which are prone to cracking, shall be cut out and rewelded.

**24.3** Tack welds shall not be made at extreme ends of joints.

## **25. Inter-Run Cleaning**

**25.1** Each run of weld bead shall be thoroughly cleaned to remove particles of slag, spatters, etc. before the subsequent bead is super-imposed during multi-pass

welding. Similarly, each layer of weld should be thoroughly cleaned of slag, spatters, etc, before depositing subsequent layers of weld with particular reference to thorough cleaning of toes of the welds. Visible defects, such as cracks, cavities and other deposition faults, if any, shall be removed to sound metal before depositing subsequent run or layer of weld.

## **26. Stray Arcing on Work**

**26.1** Stray arcing shall be avoided as this can leave local hard spots or cracking which are to be removed by mechanical means and be checked by inspection depending upon the application.

## **27. Inspection and Testing of Welded Joints**

**27.1** Inspection of the welded bridge girders carrying rail or rail-cum-road traffic whether of completely welded type or partially welded type except for foot over-bridges shall be entrusted to RDSO. Accordingly, RDSO shall undertake inspection for the first 1000 tonnes of welded plate girders after which the inspection shall be taken over by the respective zonal railways. The inspection of triangulated welded girders shall continue to be with RDSO.

**27.2** The Inspector designated by the purchaser shall ascertain that fabrication by welding is performed in accordance with the requirements of this code. Inspection of welds shall also be carried out in accordance with this Code. For the provisions which are not incorporated in this Code, IS:822 "Code of procedure for inspection of welds" shall be followed.

**27.3** He shall be furnished with complete



detailed drawings showing the size, length, type and location of all welds, which are required to be made.

**27.4** He shall be notified in advance of the start of any welding operations.

**27.5** He shall have free access to the work being done at all reasonable times by the contractor and facilities shall be provided so that during the course of welding he may be able to inspect any layer of weld metal. He shall be at liberty to reject any material that does not conform to the provisions of this code and to require any defective welds to be removed and re-welded.

## **28. Inspection Prior to Welding**

### **28.1 Parent metal**

**28.1.1** All plates and sections shall be inspected in the contractor's works before fabrication. Verification of the quality of parent metal shall be carried out by reference to the relevant test certificate. The Inspector may, at his discretion, ask for spot checks to be made on the chemical composition and physical properties of the material.

**28.1.2** Freedom from harmful defects such as cracks, surface flaws, laminations, and rough, jagged or imperfect edges shall be verified by visual examination of the material prior to welding. Dimensions of parts shall be checked by measurement.

**28.2** Edge preparation and set-up of parts.

**28.2.1** Edge preparation shall conform to the relevant drawings and meet the requirements of this code.

**28.2.2** After the parts are assembled in position for welding, the Inspector shall check for incorrect root gap, improper edge preparation and other features that might affect the quality of the welded joint.

**28.3 Verification of operator's qualification** - Welding shall be permitted to be performed only by welders and welding operators who are qualified in accordance with requirements of clause 20.

**28.4** The Contractor shall, if so required, prescribe the welding procedure to be followed. Before any welding on the actual job is allowed under the contract, the Inspector shall verify, in accordance with the provisions of IS: 9595 and IS: 4353 as applicable, that the procedure prescribed is satisfactory.

## **29. Inspection During Welding**

**29.1 Filler material** - Filler material shall be tested periodically to ensure that the specified quality is being consistently maintained.

**29.2** While welding is in progress, visual examination shall be employed to check details of work, such as proper arc, arc length, speed of weld deposit, sequence of welding, cleaning of slag after each run in multi-run welding, electrode spattering, manipulation of the electrode, employment of proper current and voltage etc. Particular care shall be taken during the early stages of the work.

## **30. Inspection After Welding**

**30.1** For visual inspection of defects, the weld surface shall be thoroughly cleaned of oxide layers and adherent slag. If chipping hammer is used to remove slag, care shall

be taken to see that hammer marks do not obscure the evidence of fine cracks. Brushing with a stiff wire-brush or grit blasting shall normally be followed.

shall be examined by radiographic test which will present satisfactory evidence to the Inspector that welds are meeting the quality requirements.

**30.2 Welding profile** - The finished welds shall be visually inspected and shall conform to the size and contour specified in the drawings (Acceptable and defective weld profiles are illustrated in Fig. 24 to 28). Conformity of fillet welds as to size and contour shall be determined by the use of gauges (See Appendix 'B') Concavity and excessive convexity of fillet welds shall be marked for correction.

**32.2** Other welds may be examined by radiographic or any other non-destructive method which are equally effective.

**32.3** Welds shall also be examined by liquid penetrant flaw detection method or by magnetic particle flaw detection method as per IS:3658 and IS:3703.

### **31. Acceptance Levels for Quality of Welds**

### **33. Marking of Defective Welds**

**31.1** Welds shall meet acceptance levels as per Appendix C.

**33.1** The marking shall be positive and clear and in accordance with the method of marking followed and understood by the Inspector and shop personnel involved in making the repairs.

**31.2 Dimensional check** - The weldment shall be inspected for dimensional accuracy (including warpage) and shall be within the tolerances specified.

**33.2** Marking shall be permanent enough to be evident until the repair is carried out and the inspection completed.

### **32. Non-destructive Tests**

**32.1 Radiographic tests** - Butt welds

**33.3** After the repair has been done, it shall be inspected again and properly marked to indicate whether the repair is satisfactory or not.

\*\*\*\*\*

### Procedure for Providing Plug Welds

- A-1 The holes shall be tapered to ensure adequate root penetration.
- A-2 Welding shall generally be carried out in flat position using a copper block plate of 25 mm minimum thickness as a backing surface. This plate shall have a depression of about 3 mm at the center and in the line of the hole.
- A-3 Electrodes conforming to IRS M-28 with type-I covering shall be used.
- A-4 For welds to be made in the flat position, the arc shall be carried round the root of the joint and then carried along spiral path to the center of the hole fusing and depositing a layer of weld metal in the root and bottom of the joint. The arc shall then be carried to the periphery of the hole and the procedure repeated, fusing and depositing successive layers to fill the hole. The slag covering the weld metal shall be kept molten, or nearly so, until the weld is finished. If the arc is broken, except briefly for changing the electrodes, the slag must be allowed to cool and be completely removed before starting the weld.
- A-5 For welds to be made in the vertical position, the arc shall be started at the root of the joint, at the lower side of the hole, and carried upwards along a zig zag path depositing a layer about 5 mm thick on the exposed face and fused to the side of the hole. After cleaning the slag from the weld, subsequent layers shall be similarly deposited to fill the hole.
- A-6 For welds to be made in the overhead position, the procedure shall be the same as for the flat position except that the slag shall be allowed to cool and shall be completely removed after depositing each layer until the hole is filled.
- A-7 All plug welds shall be finished with reinforcement of about 3 mm which shall then be dressed flush.



Acceptance Levels for Welds

| Defect Type                                                         | Permitted, Maximum                                                                                                                                                                                                                                      |
|---------------------------------------------------------------------|---------------------------------------------------------------------------------------------------------------------------------------------------------------------------------------------------------------------------------------------------------|
| <b>1) Planar defects</b>                                            |                                                                                                                                                                                                                                                         |
| a) Cracks and lamellar tears                                        | not permitted                                                                                                                                                                                                                                           |
| b) Root concavity                                                   | 0.1t or 1.2 mm whichever is less                                                                                                                                                                                                                        |
| c) Lack of root fusion                                              | not permitted                                                                                                                                                                                                                                           |
| d) Lack of side fusion                                              | not permitted                                                                                                                                                                                                                                           |
| e) Lack of inter-run fusion                                         | not permitted                                                                                                                                                                                                                                           |
| f) Lack of root penetration                                         | not permitted                                                                                                                                                                                                                                           |
| <b>2) Cavities</b>                                                  |                                                                                                                                                                                                                                                         |
| a) Isolated pores<br>(or individual pores in a group)               | $\phi \leq t/4$ and also less than<br>(i) 1.5 mm for t upto and including 25 mm;<br>or<br>(ii) 3.0 mm for t over 25 mm upto and<br>including 50 mm; or<br>(iii) 4.5 mm for t over 50 mm upto and<br>including 75 mm; or<br>(iv) 6.0 mm for t over 75 mm |
| b) Uniformly distributed or localized porosity                      | One percent by area (as seen in a radio graph) for $t \leq 25$ mm and pro-rata for greater thicknesses                                                                                                                                                  |
| c) Linear porosity                                                  | Linear porosity parallel to the axis of the weld may indicate lack of fusion or lack of penetration and is, therefore, not permitted                                                                                                                    |
| d) Worm holes, isolated                                             | $l \leq 6$ mm $w \leq 1.5$ mm                                                                                                                                                                                                                           |
| e) Worm holes, aligned                                              | same as for linear porosity                                                                                                                                                                                                                             |
| f) Crater pipes                                                     | $l \leq 6$ mm $w \leq 1.5$ mm                                                                                                                                                                                                                           |
| <b>3) Solid Inclusions (Slag Inclusions)</b>                        |                                                                                                                                                                                                                                                         |
| a) Individual and parallel to weld axis (as seen in the radiograph) |                                                                                                                                                                                                                                                         |

|                                                                 | t                 | l                                                                                                                                          | w       |
|-----------------------------------------------------------------|-------------------|--------------------------------------------------------------------------------------------------------------------------------------------|---------|
| i)                                                              | ≤18 mm            | ≤ t/2 and ≤6 mm                                                                                                                            | ≤1.5 mm |
| ii)                                                             | >18 mm and ≤75 mm | ≤ t/3                                                                                                                                      | ≤1.5 mm |
| iii)                                                            | >75 mm            | ≤ 25 mm                                                                                                                                    | ≤1.5 mm |
| b) Linear group*                                                |                   | Aggregate length should not exceed 8 percent of length of group, which in turn should not exceed 12t in length                             |         |
| c) Individual and randomly oriented (Not parallel to weld axis) |                   | Maximum dimension in any direction: 6 mm                                                                                                   |         |
| <b>4) Copper inclusions</b>                                     |                   |                                                                                                                                            |         |
| (Detected by visual examination or by radiography)              |                   | Not permitted                                                                                                                              |         |
| <b>5) Profile defects</b>                                       |                   |                                                                                                                                            |         |
| a) Undercut                                                     |                   | Slight intermittent undercut permitted, provided it does not form a sharp notch ; depth should not exceed 0.4 mm                           |         |
| b) Shrinkage grooves and root concavity                         |                   | Same as for under cut, depth should not exceed 1.2 mm                                                                                      |         |
| c) Excess penetration                                           |                   | h≤3 mm. Occasional local slight excess is allowable                                                                                        |         |
| d) Reinforcement shape                                          |                   | The reinforcement shall blend smoothly with the parent metal and dressing shall be as specified in drawing or required for NDT techniques. |         |
| e) Overlap                                                      |                   | Not permitted                                                                                                                              |         |
| f) Linear misalignment                                          |                   | h≤t/10 and ≤ 3 mm                                                                                                                          |         |
| g) Other profile defects                                        |                   | As per Clause 30.2                                                                                                                         |         |

**Symbols:**

- t = Thickness of parent metal. In the case of dissimilar thicknesses t applies to the thinner component
- w = Width of defect
- l = Length of defect
- h = Height of defect
- ∅ = Diameter of defect

- Individual inclusions within the group should not exceed the sizes in 3(a) above. A linear group is defined as a number of inclusions in line and parallel to the weld axis where the spacing between their adjacent ends does not exceed 6 times the length of the longest inclusion within the group. With parallel groups, all inclusions count towards the aggregate.

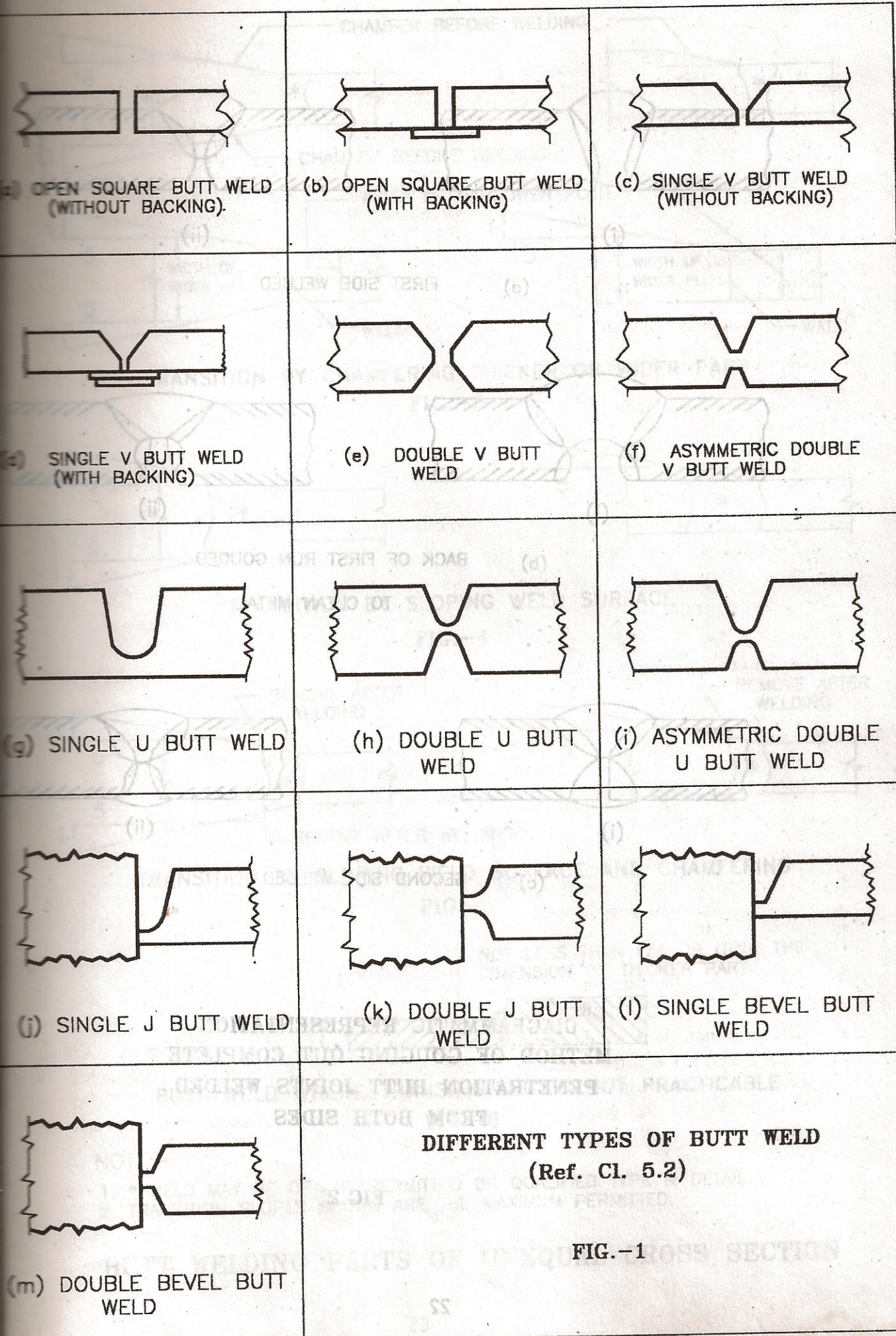

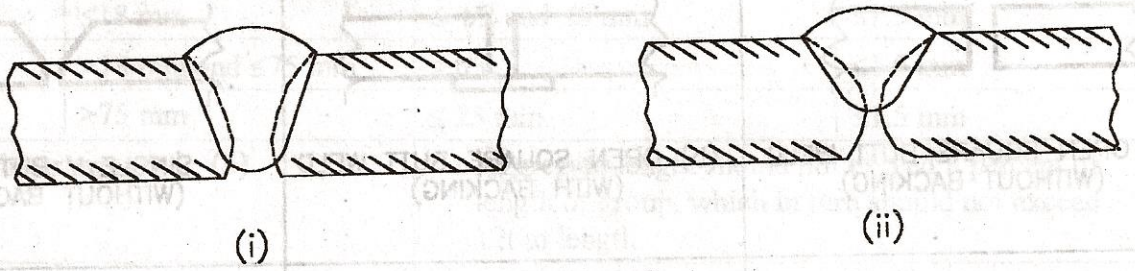

(a) FIRST SIDE WELDED

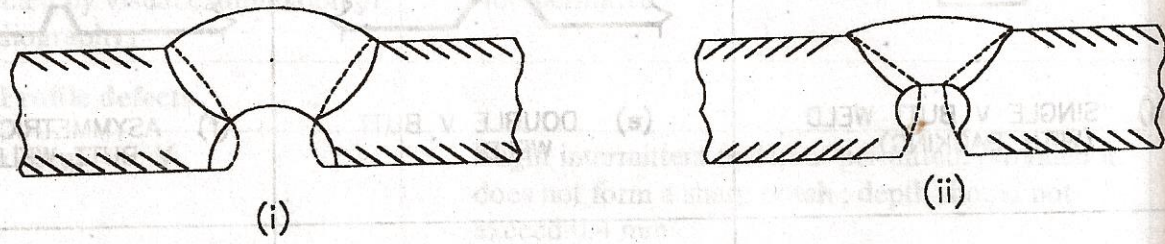

(b) BACK OF FIRST RUN GOUGED TO CLEAN METAL

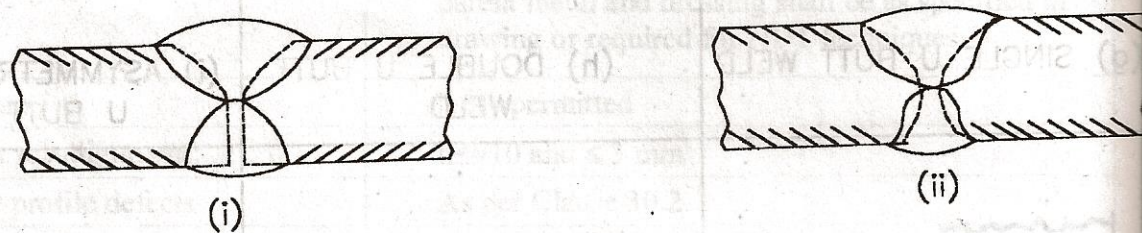

(c) SECOND SIDE WELDED

**DIAGRAMMATIC REPRESENTATION  
METHOD OF GOUGING OUT COMPLETE  
PENETRATION BUTT JOINTS WELDED  
FROM BOTH SIDES**

**FIG.2**



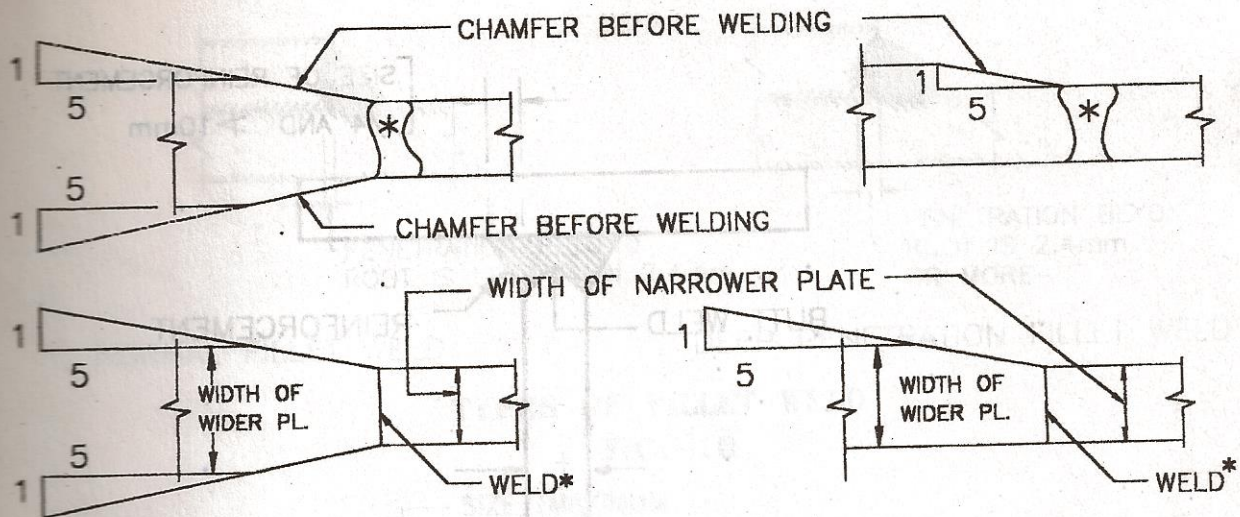

TRANSITION BY CHAMFERING THICKER OR WIDER PART

FIG.-3

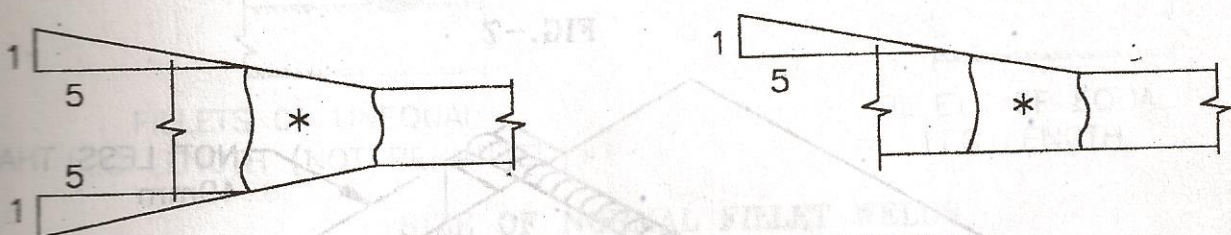

TRANSITION BY SLOPING WELD SURFACE

FIG.-4

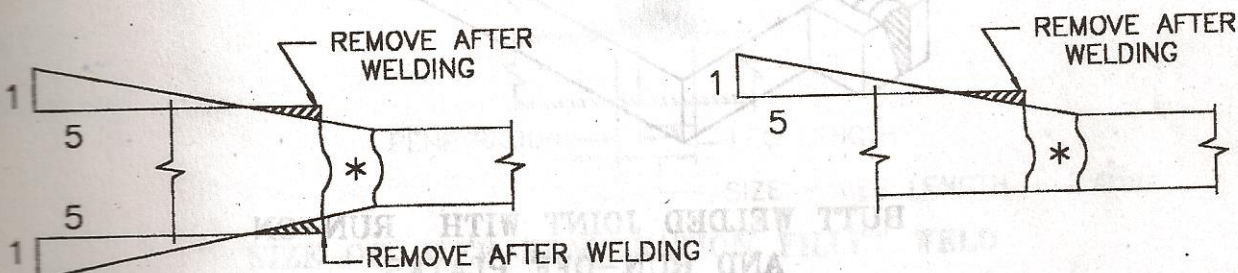

TRANSITION BY SLOPING WELD SURFACE AND CHAMFERING

FIG.-5

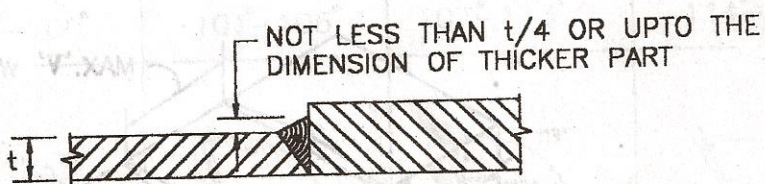

BUTT WELD WHERE TRANSITIONING IS NOT PRACTICABLE

FIG.-6

NOTE:-

1. \* WELD MAY BE OF ANY PERMITTED OR QUALIFIED TYPE & DETAIL.
2. TRANSITION SLOPES SHOWN ARE THE MAXIMUM PERMITTED.

BUTT WELDING PARTS OF UNEQUAL CROSS SECTION

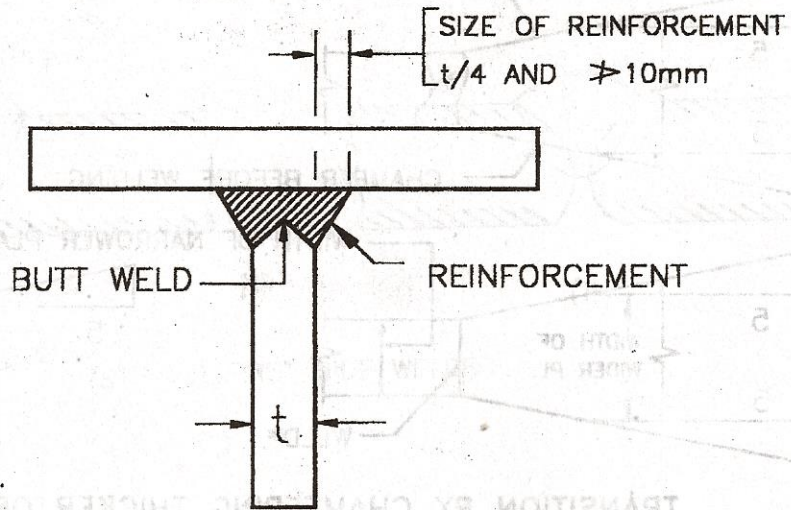

**BUTT WELDED T JOINT**

**FIG.-7**

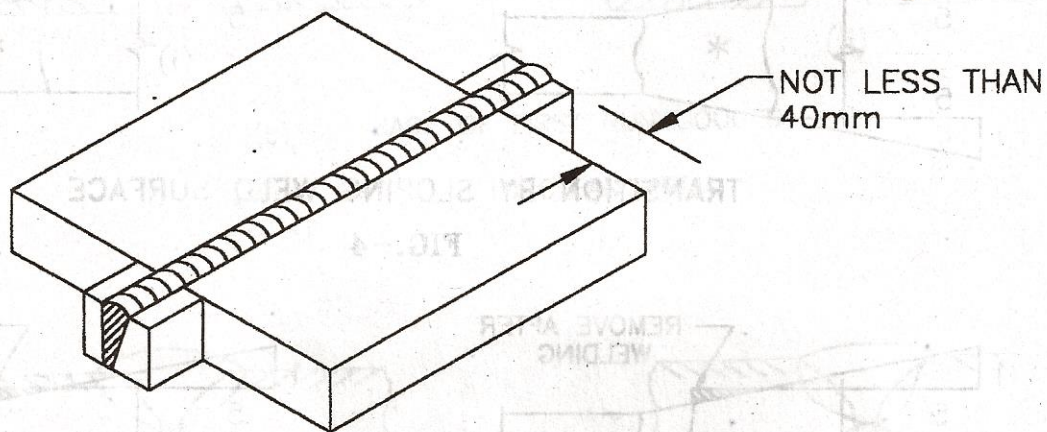

**BUTT WELDED JOINT WITH RUN-ON AND RUN-OFF PLATES**

**FIG.-8**

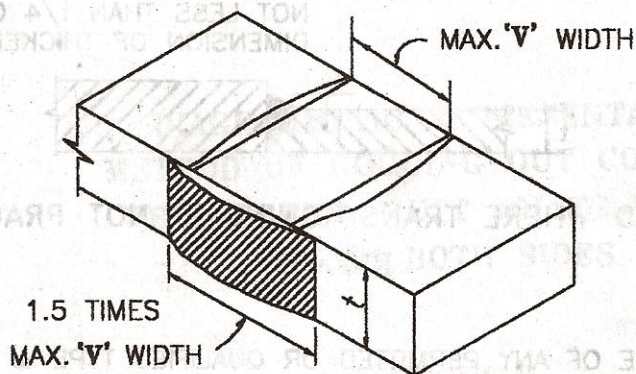

**BUTT WELD END REINFORCEMENT**

**FIG.-9**

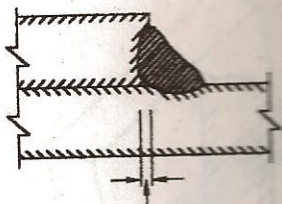

PENETRATION BEYOND ROOT IS LESS THAN 2.4mm

NORMAL FILLET WELD

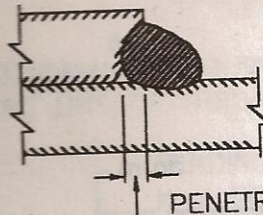

PENETRATION BEYOND ROOT IS 2.4mm OR MORE

DEEP PENETRATION FILLET WELD

TYPES OF FILLET WELD

FIG.-10

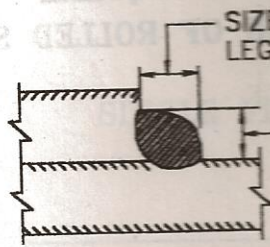

FILLETS OF UNEQUAL LEG LENGTH (NOT PERMITTED)

SIZE (MAXIMUM LEG LENGTH)  
SIZE (MINIMUM LEG LENGTH)

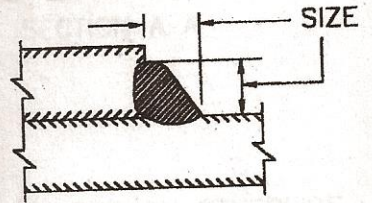

FILLETS OF EQUAL LEG LENGTH

SIZE OF NORMAL FILLET WELDS

FIG.-11

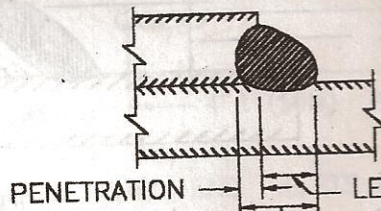

PENETRATION — LEG LENGTH

SIZE = LEG LENGTH + 2.4mm

SIZE OF DEEP PENETRATION FILLET WELD

FIG.-12

| ANGLE BETWEEN FUSION FACES | 60°-90° | 91°-100° | 101°-106° | 107°-113° | 114°-120° |
|----------------------------|---------|----------|-----------|-----------|-----------|
|                            |         |          |           |           |           |
| CONSTANT 'K'               | 0.70    | 0.65     | 0.60      | 0.55      | 0.50      |

FIG.-13

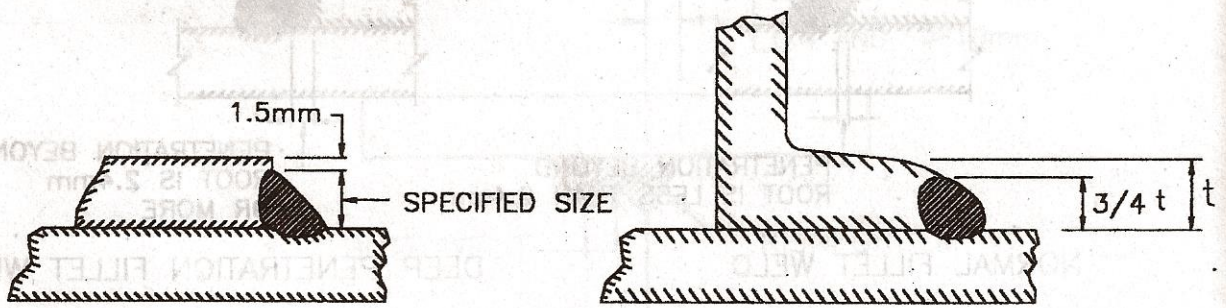

**FILLET WELD APPLIED TO SQUARE  
EDGE OF PLATE OR ROUND TOE OF ROLLED SECTION**

**FIG.-14**

BUILT OUT HERE TO ENSURE  
NO DEFICIENCY OF SIZE OR  
EFFECTIVE THROAT THICKNESS  
REQUIRED SIZE =  $t$

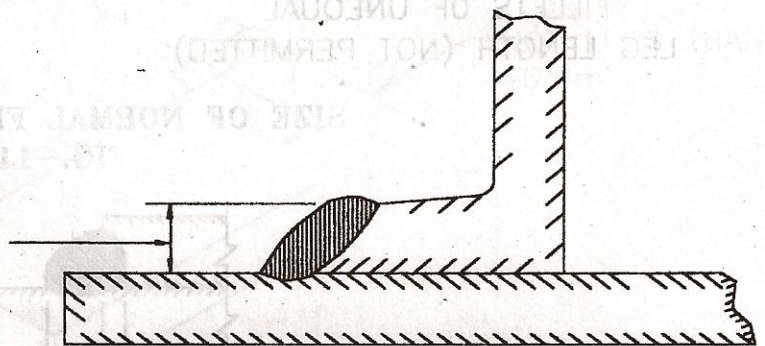

**FIG.-15**



(a) ACCEPTABLE - REQUIRED THROAT THICKNESS OBTAINED

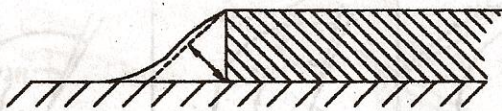

(b) ACCEPTABLE - REQUIRED THROAT THICKNESS OBTAINED

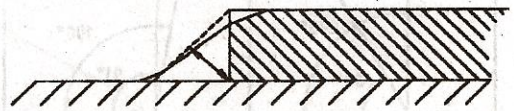

(c) NOT ACCEPTABLE - REQUIRED THROAT THICKNESS NOT OBTAINED

**FILLET WELD EQUAL TO THE SIZE OF PLATE OR SECTION**

**FIG.-16**

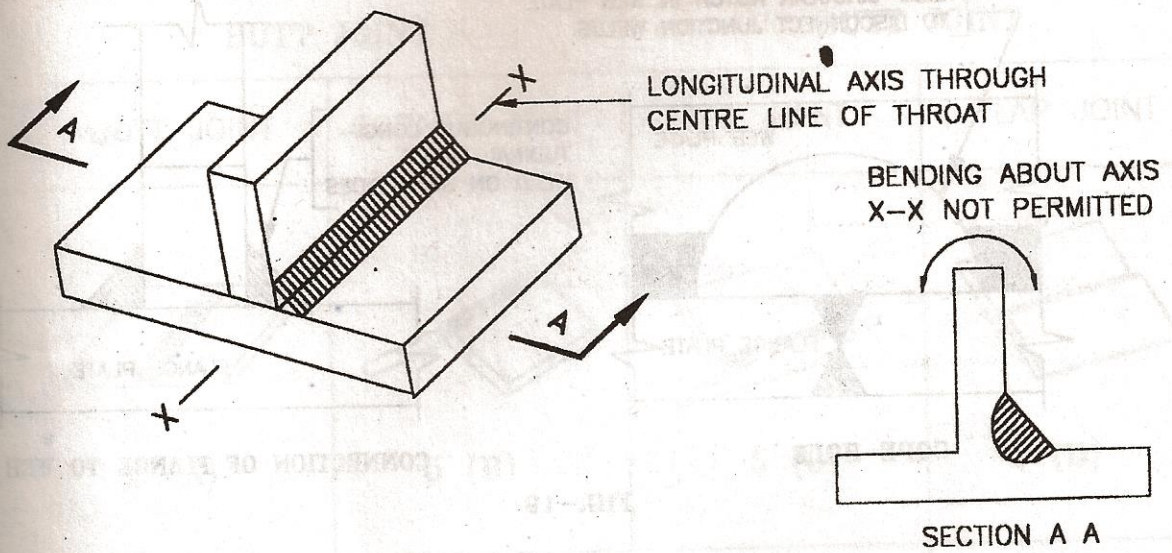

**SINGLE FILLET WELD BENDING**  
**FIG.-17**

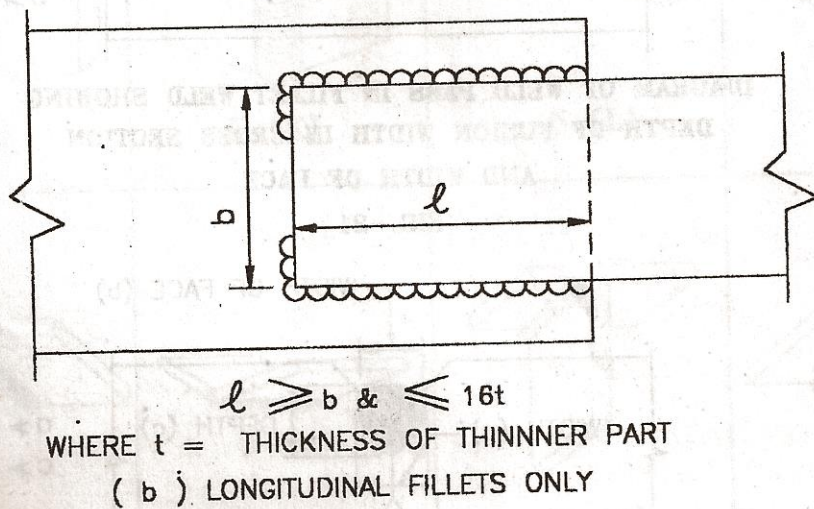
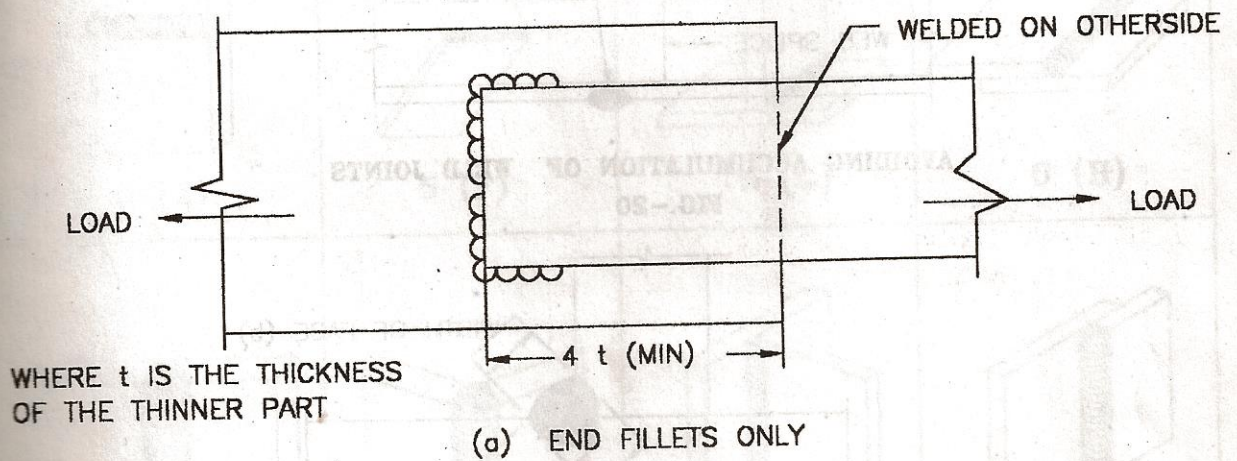

**FILLET WELDS IN LAP JOINTS**  
**FIG.-18**

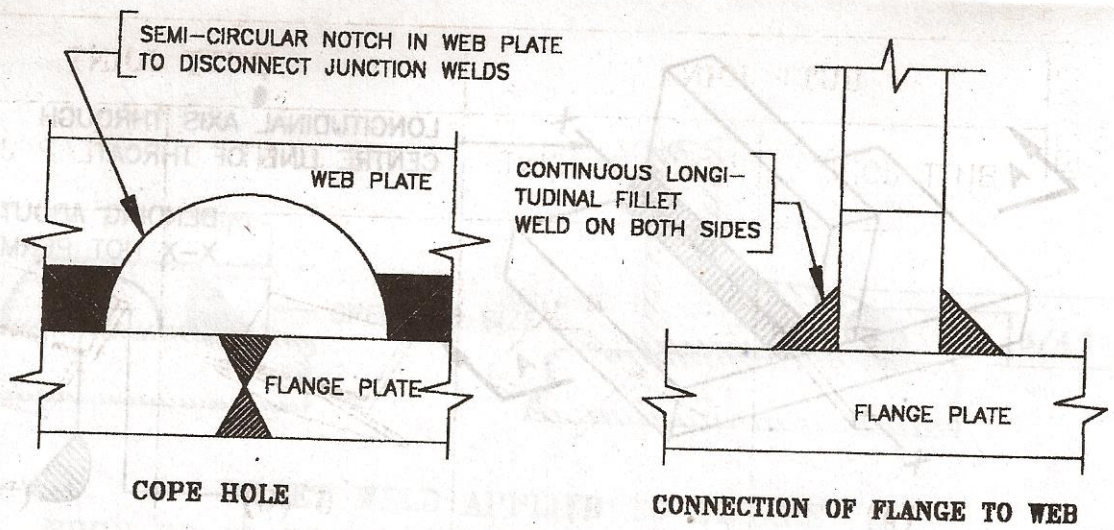
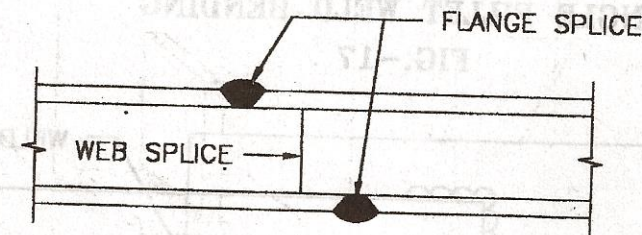

FIG.-19



AVOIDING ACCUMULATION OF WELD JOINTS

FIG.-20

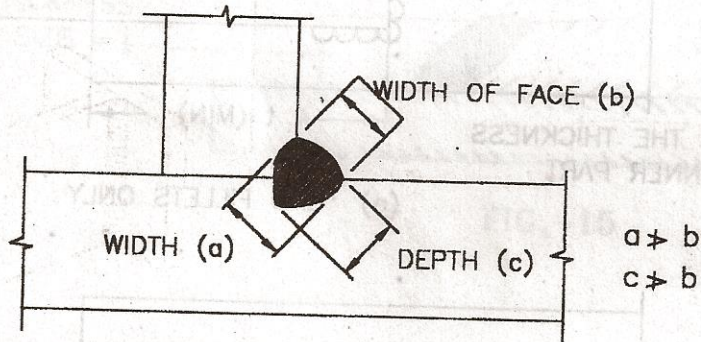

DIAGRAM OF WELD PASS IN FILLET WELD SHOWING DEPTH OF FUSION WIDTH IN CROSS SECTION AND WIDTH OF FACE

FIG.-21

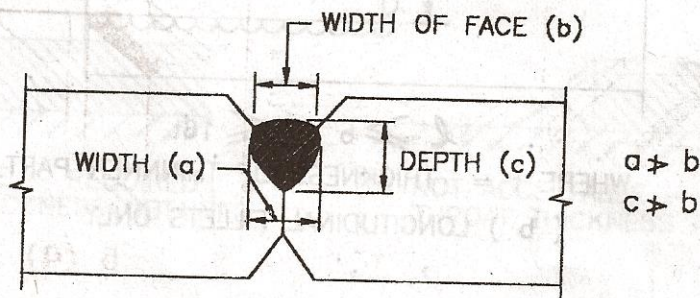
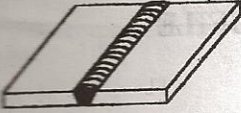
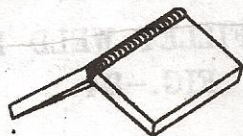
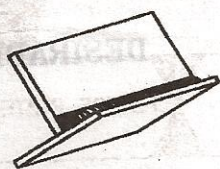
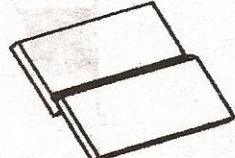
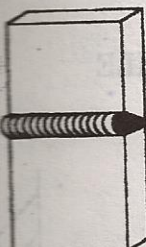

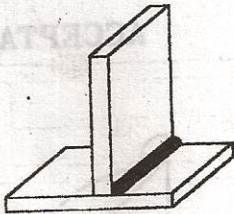

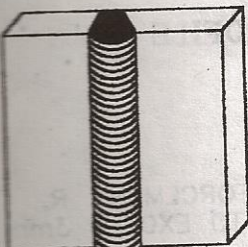
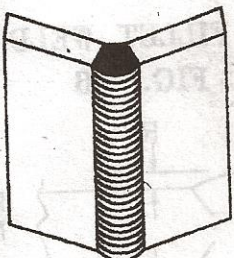
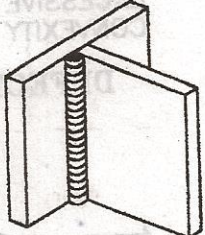
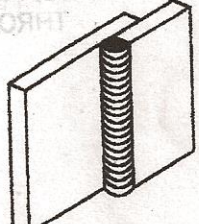

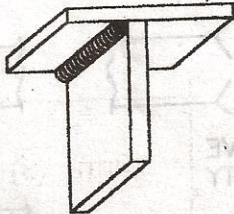



DIAGRAM OF WELD PASS IN BUTT WELD SHOWING DEPTH OF FUSION IN CROSS SECTION AND WIDTH OF FACE

FIG.-22

| POSITION OF WELDING   | BUTT JOINT                                                                                   |                                                                                              | BUTT JOINT                                                                                    |                                                                                                |
|-----------------------|----------------------------------------------------------------------------------------------|----------------------------------------------------------------------------------------------|-----------------------------------------------------------------------------------------------|------------------------------------------------------------------------------------------------|
|                       | BUTT JOINT                                                                                   | CORNER JOINT                                                                                 | TEE JOINT                                                                                     | LAP JOINT                                                                                      |
| FLAT                  | <br>5 (A)   | <br>5 (B)   | <br>5 (C)   | <br>5 (D)   |
| HORIZONTAL - VERTICAL | <br>5 (E)   | <br>5 (F)   | <br>5 (G)   | <br>5 (H)   |
| VERTICAL              | <br>5 (J) | <br>5 (K) | <br>5 (L) | <br>5 (M) |
| OVERHEAD              | <br>5 (N) | <br>5 (P) | <br>5 (Q) | <br>5 (R) |

POSITION OF WELDING

(Ref. Cl. - 23)

FIG.-23

# ACCEPTABLE AND DEFECTIVE WELD PROFILES

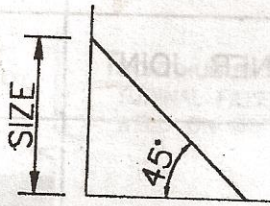

**DESIRABLE FILLET WELD PROFILE**  
FIG.-24

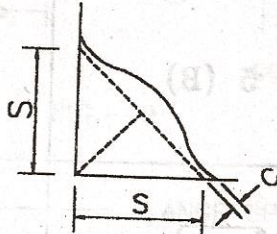

CONVEXITY C NOT TO EXCEED  $0.1 S + 0.76 \text{mm}$

**ACCEPTABLE FILLET WELD PROFILE**  
FIG.-25

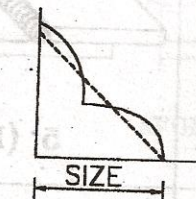

INSUFFICIENT THROAT

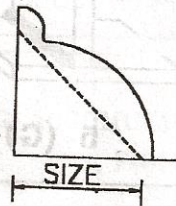

EXCESSIVE CONVEXITY

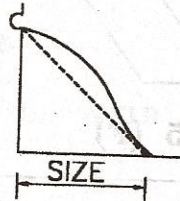

EXCESSIVE UNDER CUT

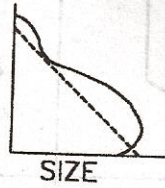

OVERLAP

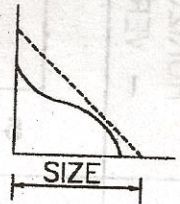

INSUFFICIENT LEG

**DEFECTIVE FILLET WELD PROFILE**  
FIG.-26

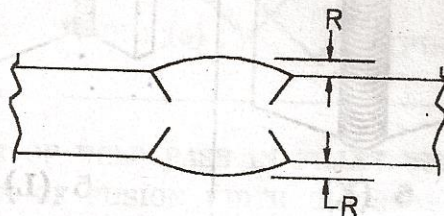

REINFORCEMENT, R, NOT TO EXCEED 3mm

**ACCEPTABLE BUTT WELD PROFILE**  
FIG.-27

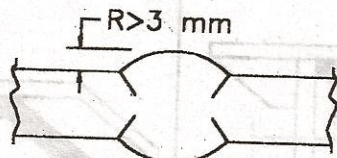

EXCESSIVE CONVEXITY



UNDER CUT



OVERLAP



INSUFFICIENT THROAT

**DEFECTIVE BUTT WELD PROFILES**  
FIG.-28